

Technical Data	U.S. Units	Metric Units
Body Type	Line mount	
Weight	1.578 lb.	0,716 kg.
Capacity	12 gpm	45 L/min.
Mounting Hole Diameter	.34 in.	8.6 mm
Mounting Hole Depth	Through	
Mounting Hole Quantity	2	

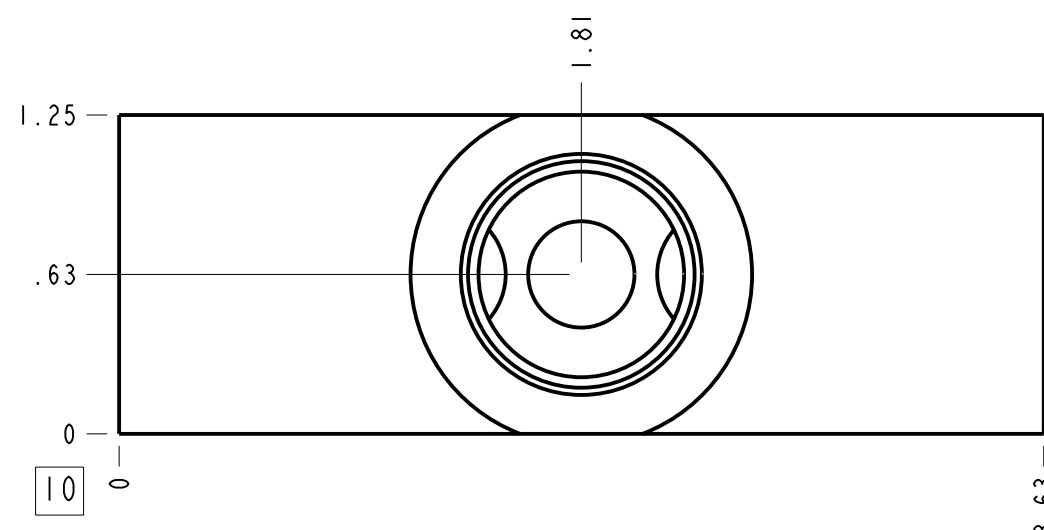
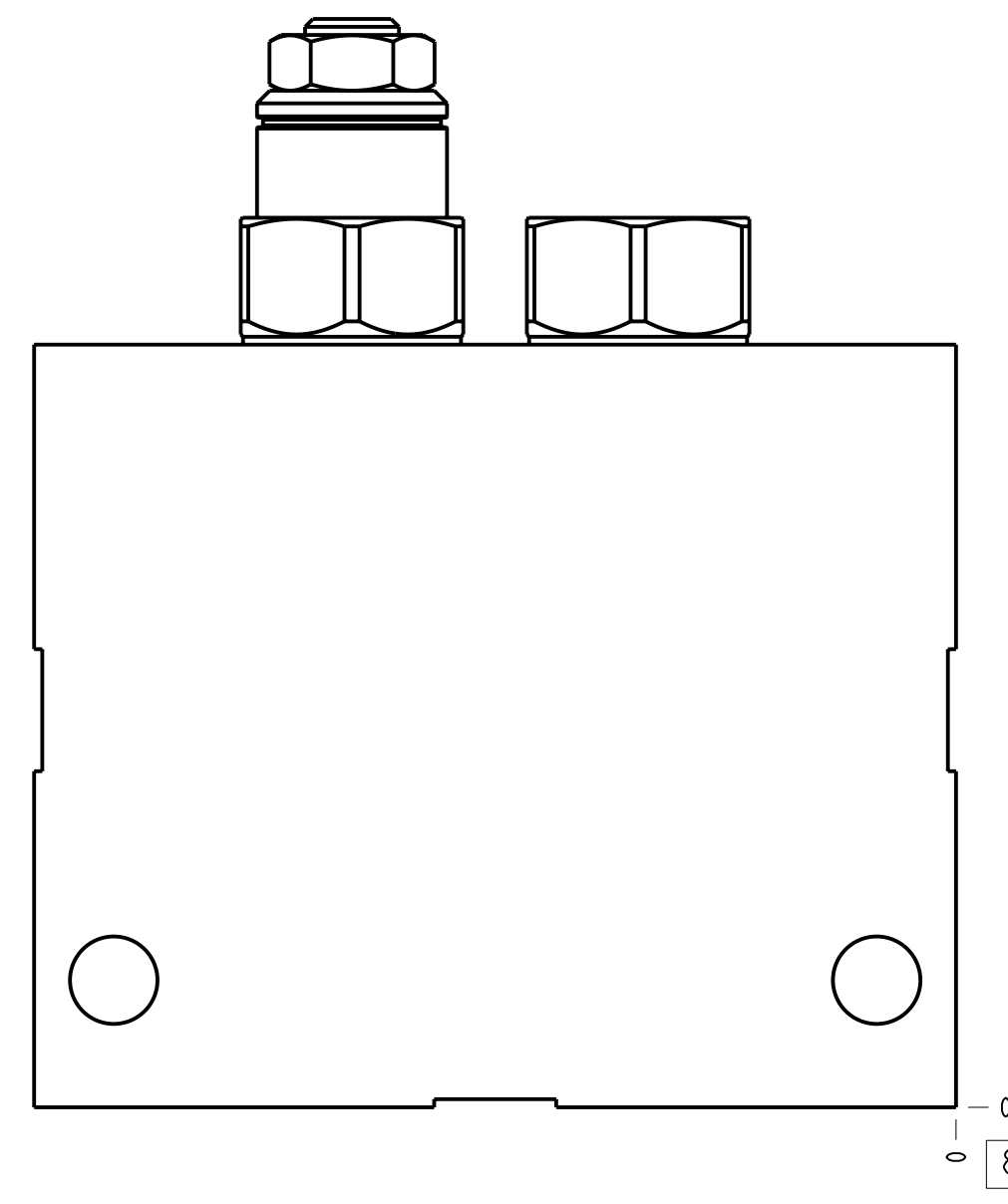
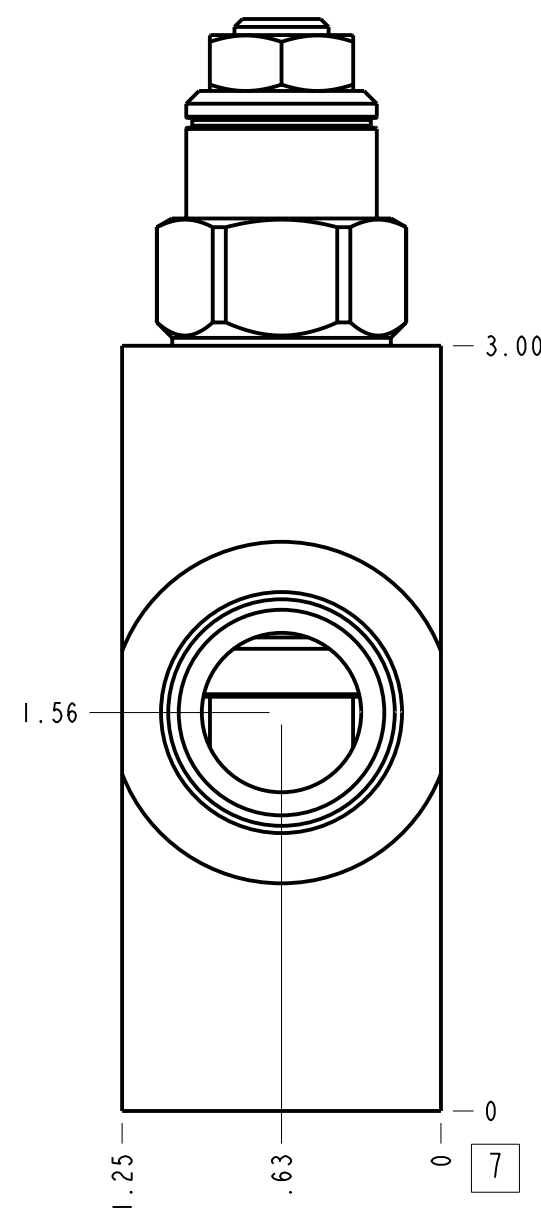
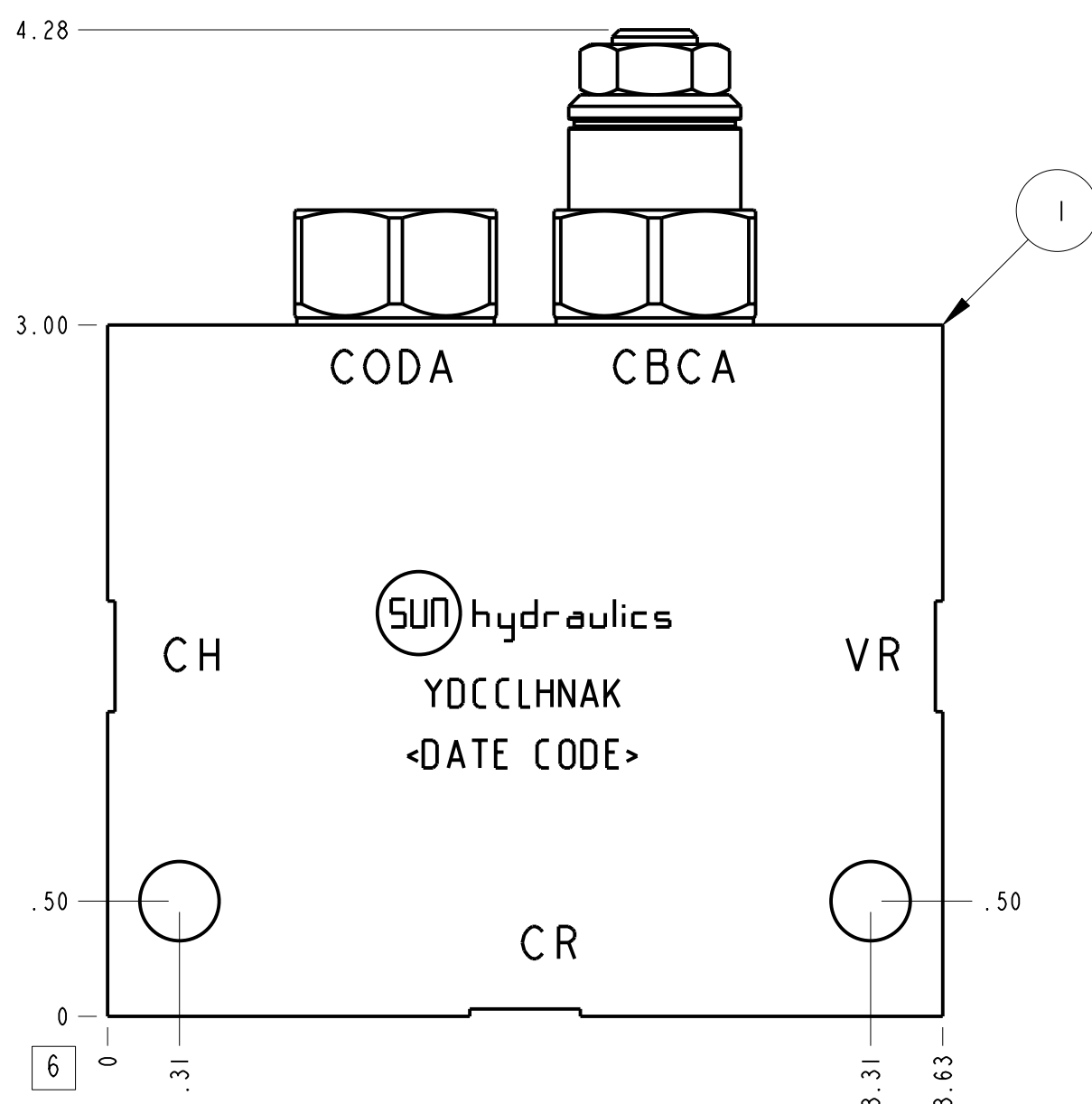
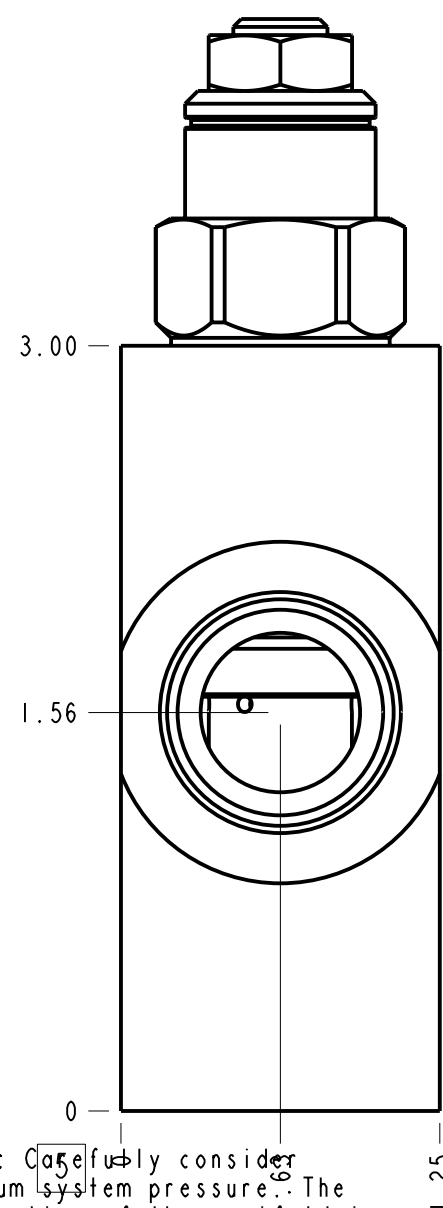

Notes

- Important: Carefully consider the maximum system pressure. The pressure rating of the manifold is dependent on the manifold material, with the port type/size a secondary consideration. Manifolds constructed of aluminum are not rated for pressures higher than 3000 psi (210 bar), regardless of the port type/size specified.
- For detailed information regarding the cartridges contained in this assembly, click on the models codes shown in the Included Components tab.
- This drawing is for reference only. It is generated by an automated process and does not fall under Sun's document control process.

Port Headings		
Product	Port	Size
YDCCLHNAK	Ports CH, CR, VR	SAE 10

3	CBCA-LHN			COUNTERBALANCE VALVE	1
2	CODA-XEN			CHECK VALVE	1
1	150-816-002		6061-T6 ALUMINUM	BODY	1
ITEM	PART NO.	SETTING	MATERIAL	PART NAME	QTY

MODEL	YDCCLHNAK		ALL DIMENSIONS IN INCH VIEWS ARE THIRD ANGLE			FIRST ANGLE	THIRD ANGLE
DESCRIPTION	Line mount		DATE	SCALE	DWG SIZE	SHEET	
			Mar-05-24	1.329	C	1	