

Relief P to T

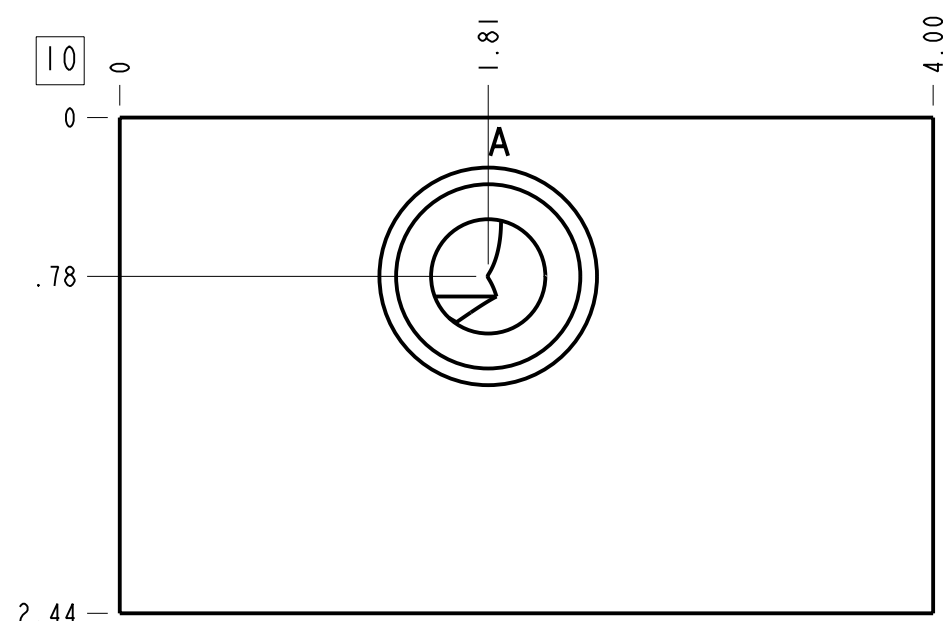
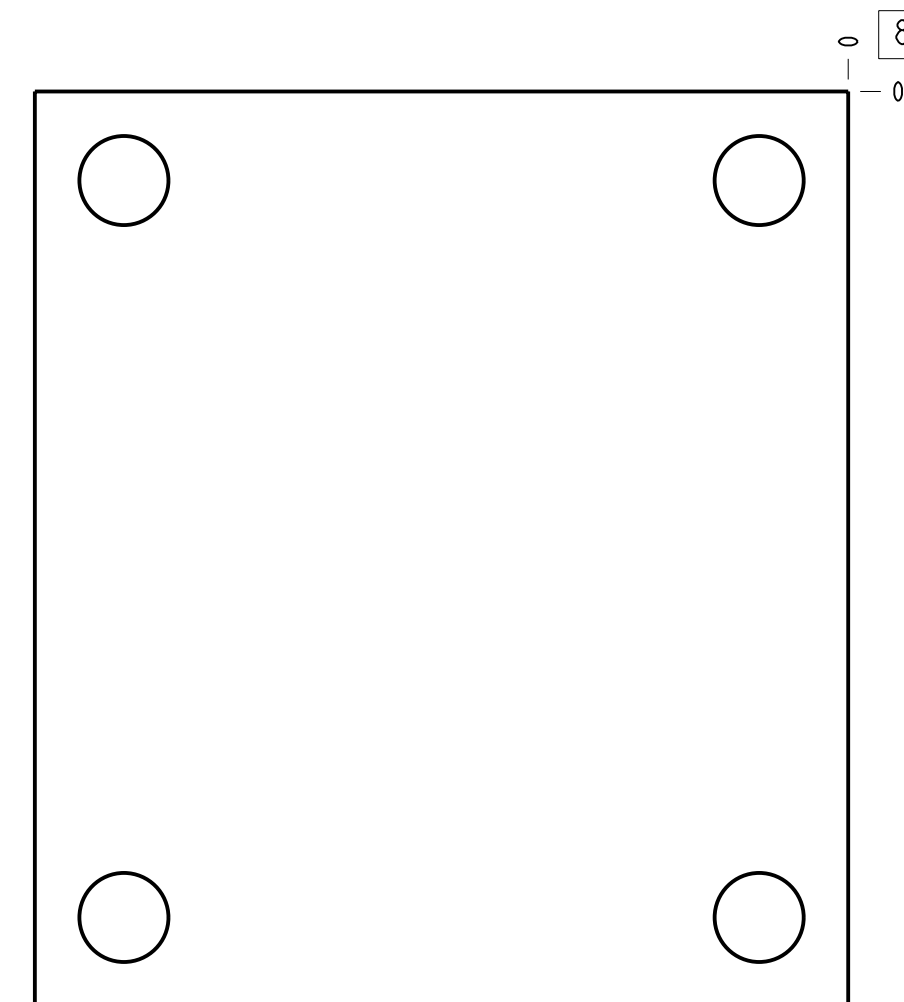
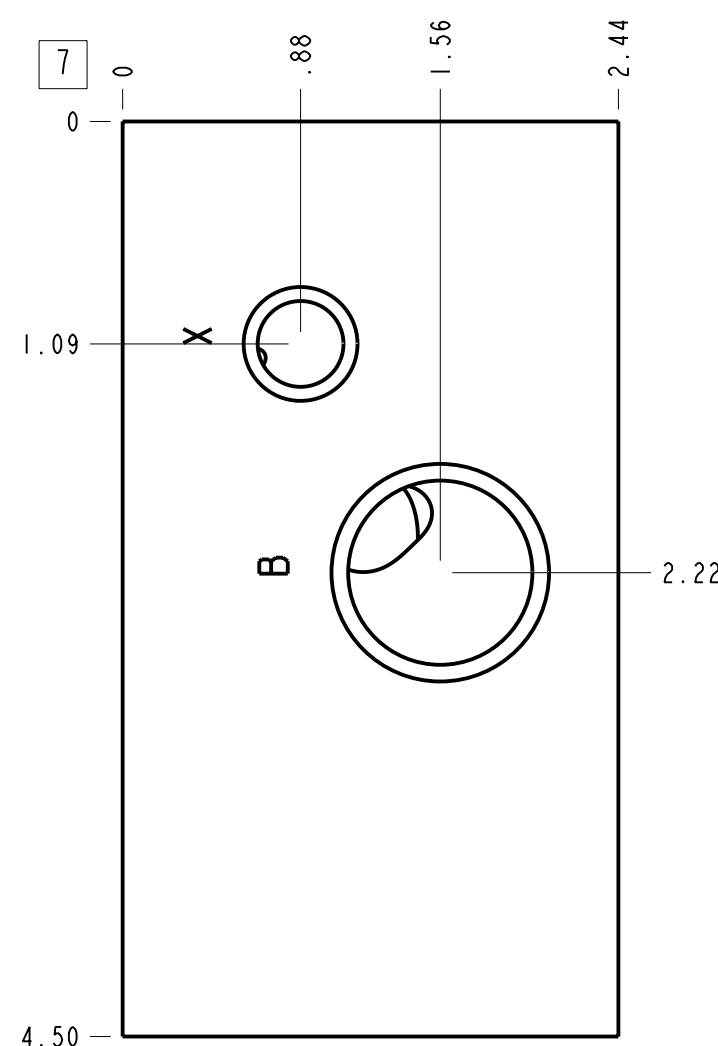
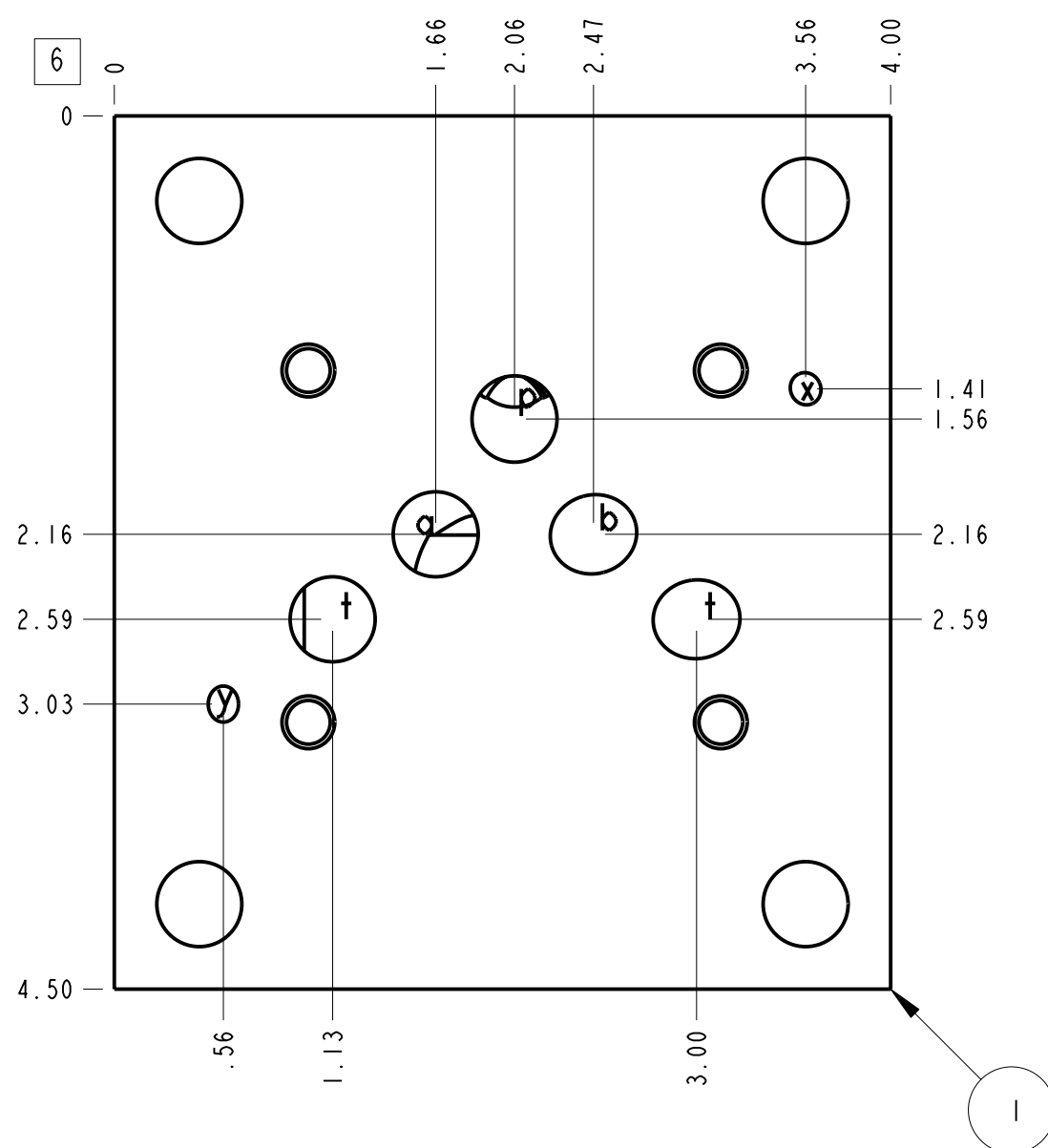
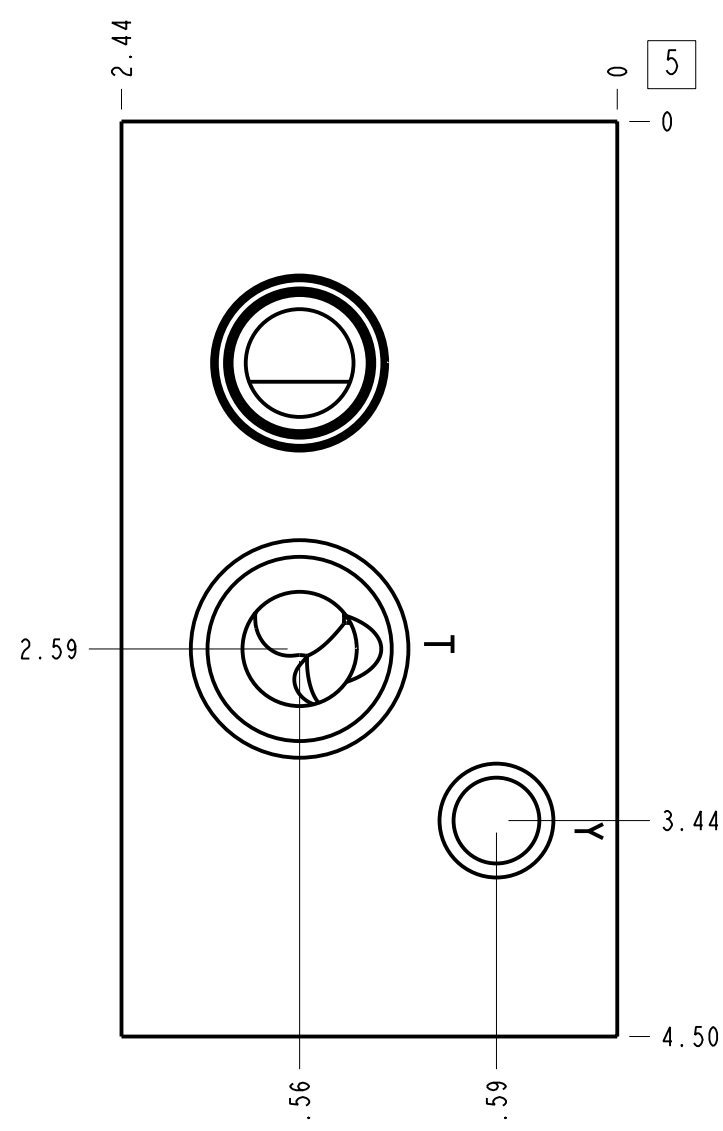
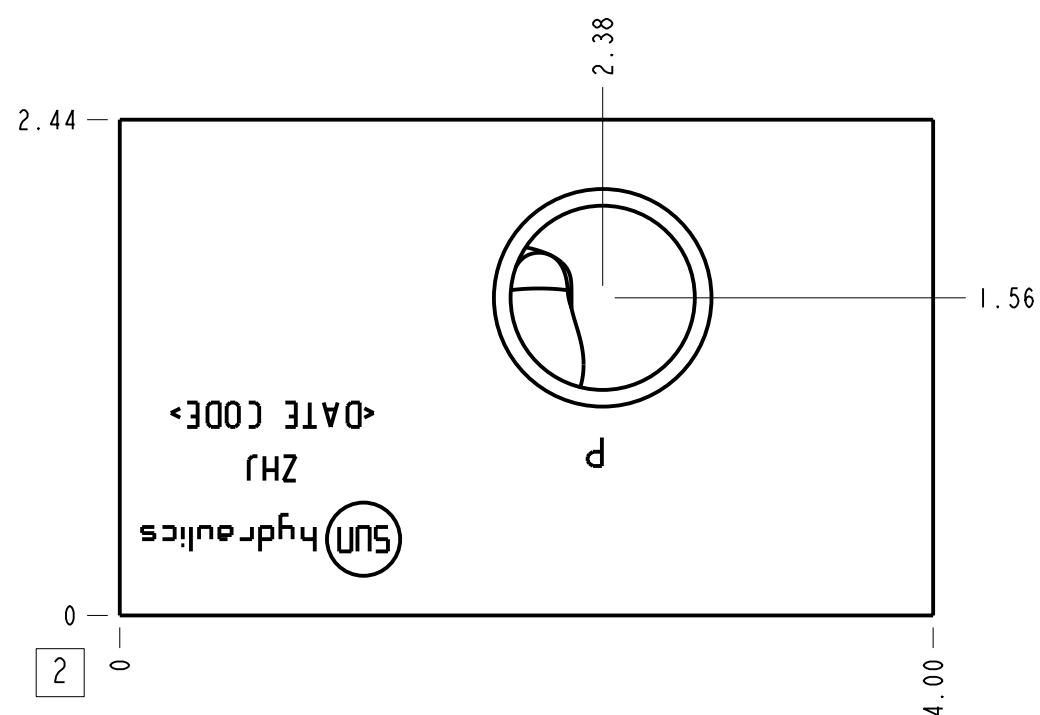

Technical Data	U.S. Units	Metric Units
Cavity	T-10A	
Body Features	P to T, side ports	
Body Type	Subplate	
Interface	ISO 05 - X&Y (US)	
Open Cavity Quantity	1	
Weight	3.574 lb.	1,621 kg.
Mounting Hole Diameter	.44 in.	11,1 mm
Mounting Hole Depth	Through	
Mounting Hole Quantity	4	

Notes

- Important: Carefully consider the maximum system pressure. The pressure rating of the manifold is dependent on the manifold material, with the port type/size a secondary consideration. Manifolds constructed of aluminum are not rated for pressures higher than 3000 psi (210 bar), regardless of the port type/size specified.
- This drawing is for reference only. It is generated by an automated process and does not fall under Sun's document control process.

Port Headings		
Product	Port	Size
ZHZ	Ports A, B, P, T	3/4" NPTF
ZHZ	Ports X & Y	1/4" NPTF

MODEL	151-649-002	6061-T6 ALUMINUM	BODY	1
ITEM	PART NO.	SETTING	MATERIAL	PART NAME
DESCRIPTION		ALL DIMENSIONS IN INCH VIEWS ARE THIRD ANGLE		QTY
T-10A Subplate ISO 05 - X&Y (US) P to T, side ports		DATE	SCALE	DWG SIZE SHEET
		Jun-28-23	1.059	C 1