

Technical Data	U.S. Units	Metric Units
Cavity	T-17A	
Body Features	Ninety degree with reverse flow check - sequence	
Body Type	Line mount	
Interface	None	
Open Cavity Quantity	1	
Weight	6.310 lb.	2,862 kg.
Mounting Hole Diameter	.41 in.	10,4 mm
Mounting Hole Depth	Through	
Mounting Hole Quantity	2	
Includes integral cartridge(s)	Yes (see Included Components)	

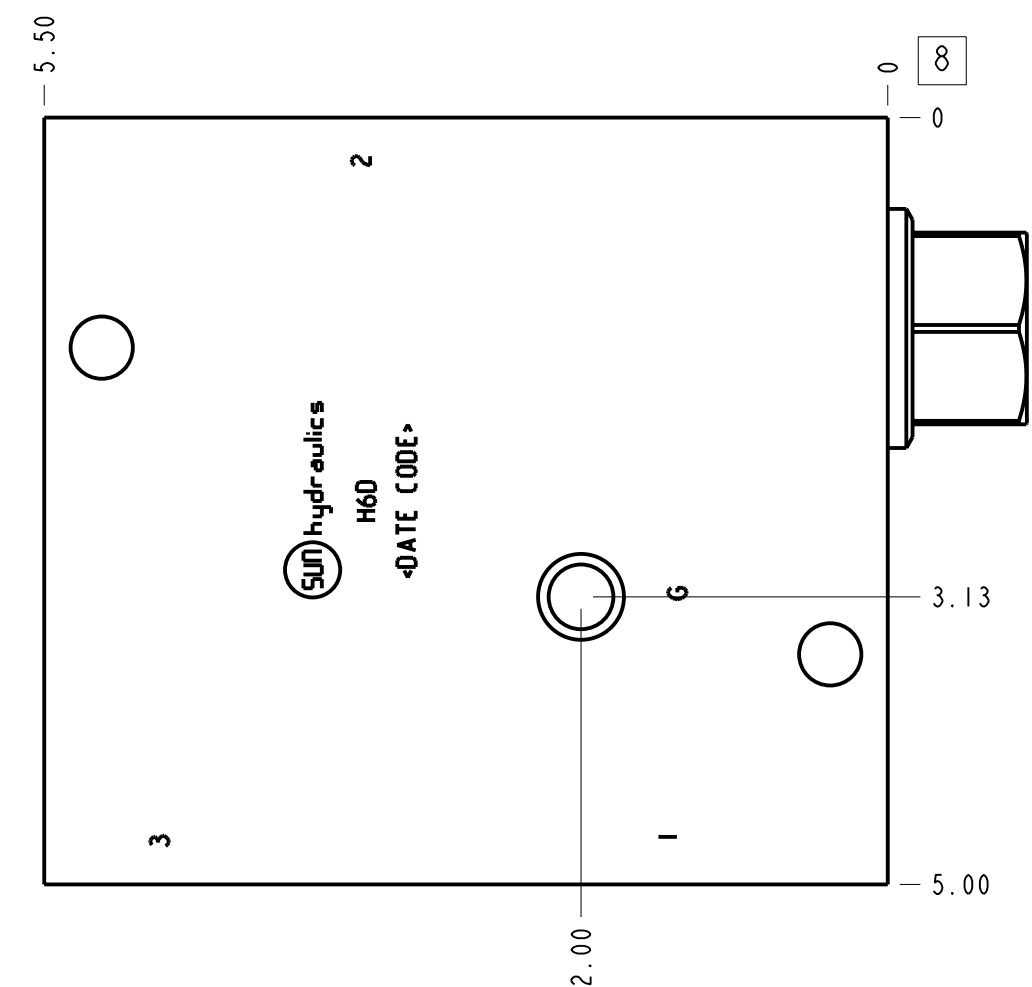

**Notes**

- Important: Carefully consider the maximum system pressure. The pressure rating of the manifold is dependent on the manifold material, with the port type/size a secondary consideration. Manifolds constructed of aluminum are not rated for pressures higher than 3000 psi (210 bar), regardless of the port type/size specified.
- This drawing is for reference only. It is generated by an automated process and does not fall under Sun's document control process.

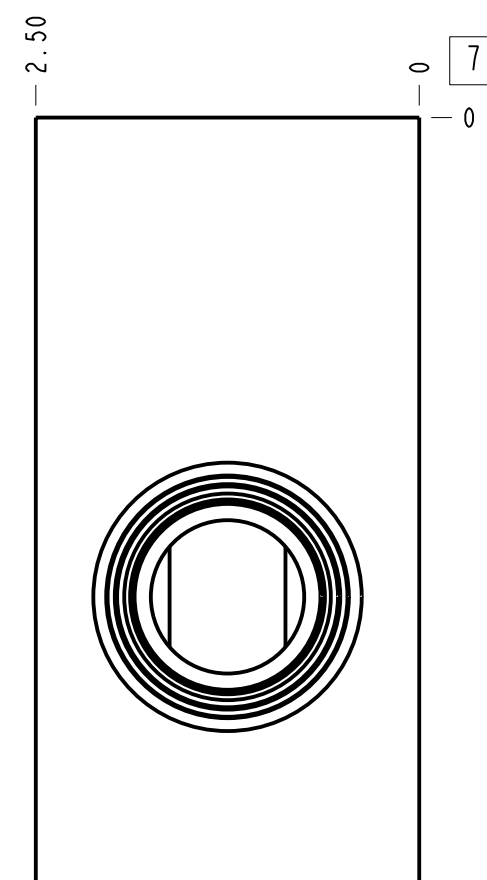
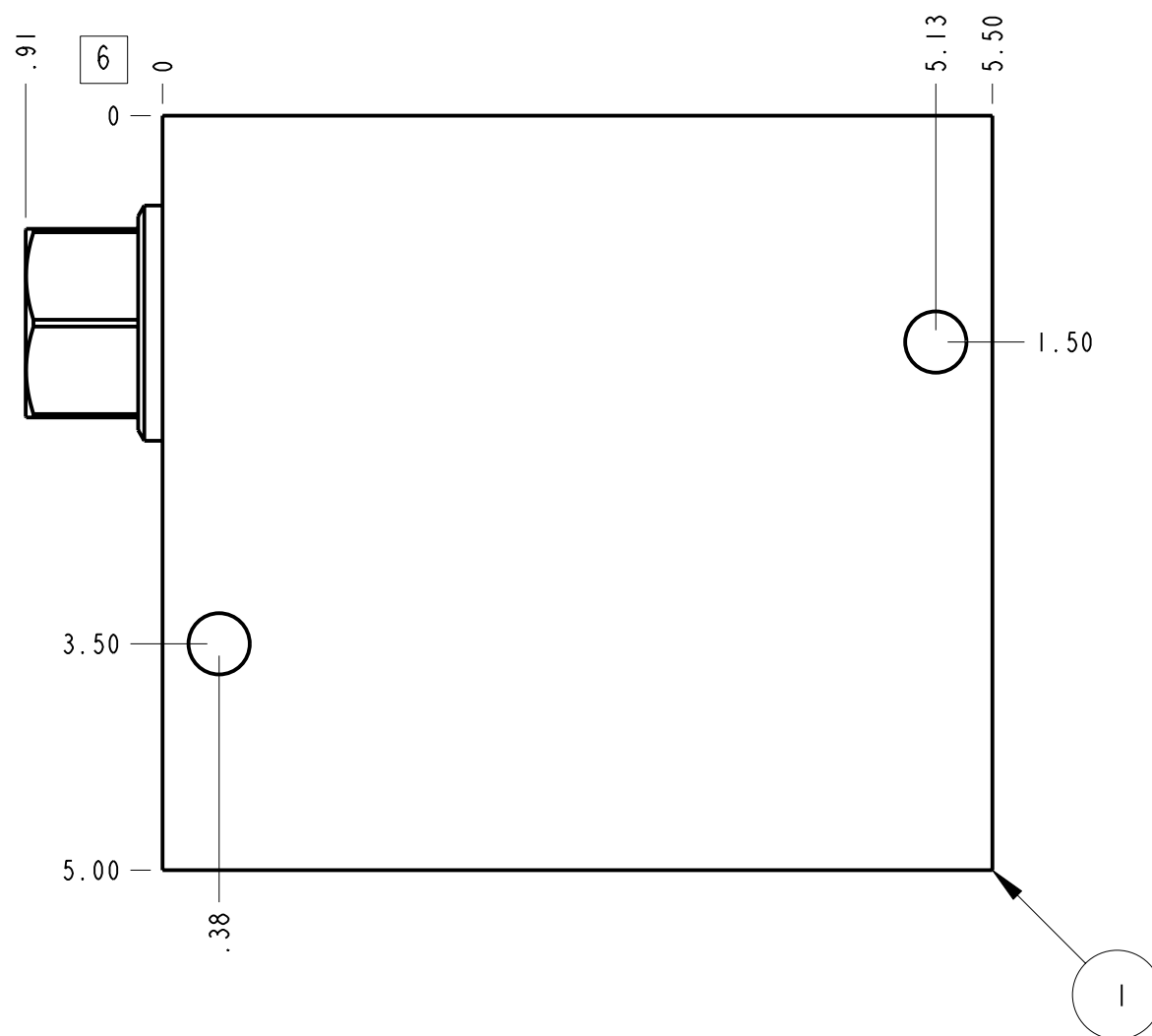
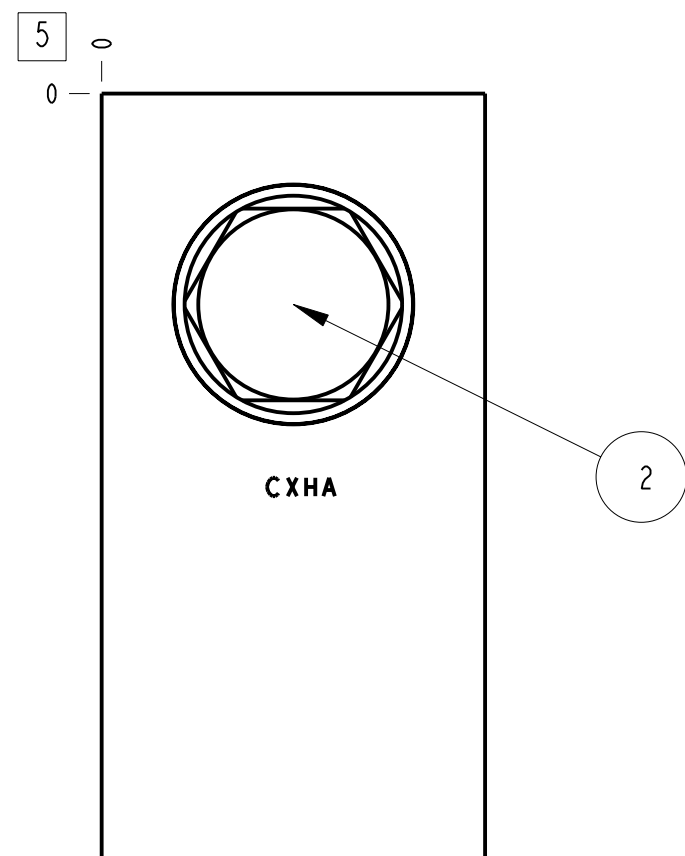
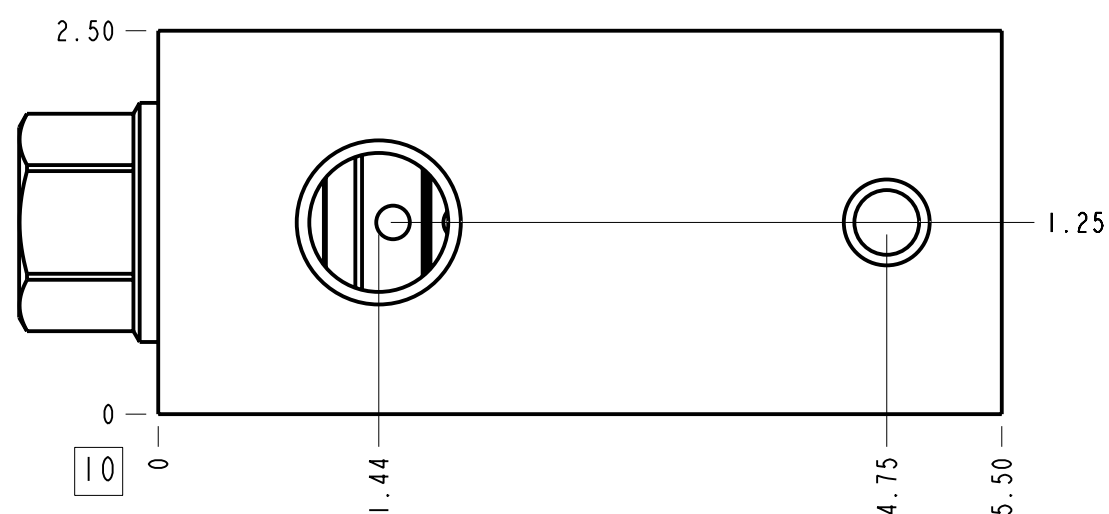

Port Headings		
Product	Port	Size
H6D	Ports 1 & 2	3/4" NPTF
H6D	Port 3	1/4" NPTF
H6D	Gage Port	1/4" NPTF

2	CXHAXCN		CHECK VALVE	1	
1	150-755-001	6061-T6 ALUMINUM	BODY	1	
ITEM	PART NO.	SETTING	MATERIAL	PART NAME	QTY
MODEL	H6D		ALL DIMENSIONS IN INCH VIEWS ARE THIRD ANGLE		
DESCRIPTION	T-17A Line mount (See Technical Data for Body Features)		DATE	SCALE	DWG SIZE SHEET
			Nov-01-24	0.799	C 1